

# External Bus Interface (EBI)

## BA318

FactSheet

### General description

An External Bus Interface (EBI) is used to share I/O pins controlling one or more memory devices that are connected to two different memory controllers. This allows to reduce the total system pin count, and thus the system cost.

As shown in Fig. 1 below, both address and data busses can be shared between memory controllers while Chip Select signals are not shared, since they are used to select devices. Depending on the application, all other control pins can also be shared.

Both arbitration & handshake processes are very classical. Refer to the datasheet for more details.

### Technical Description

**Maximum Frequency - (90nm ASIC technology)**

- HCLK: 200MHz

#### Deliverables

- RTL sources;
- TestBench;
- Documentation;

#### Implementation Data

- 1kgates (Scan included)

#### Maturity/Silicon-proven

- Silicon-proven with several implementations in different technologies.

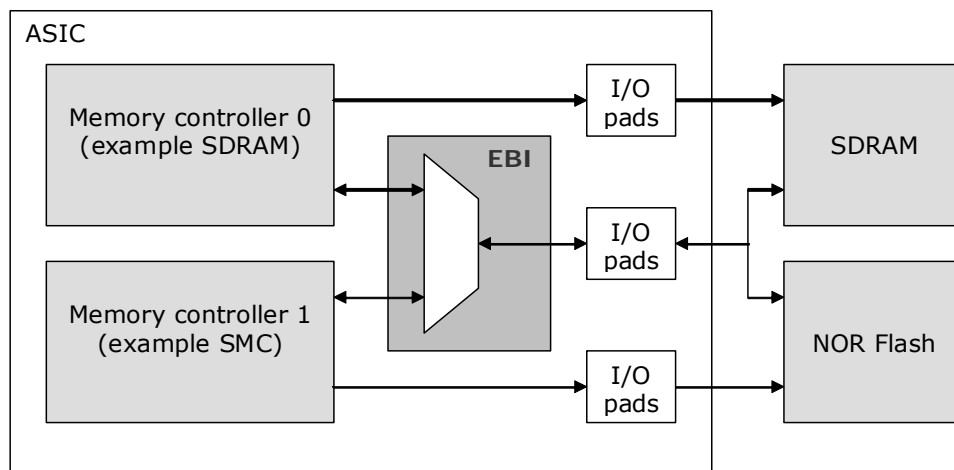

Figure 1 – Use of the BA318-EBI in a SoC

## Barco Silex overview

Barco Silex is a micro-electronic design house located in Belgium and France belonging to the Belgian Barco group.

Barco Silex offers a complete portfolio of high-end design services, from ASIC/FPGA design to advanced SoC/SoPC based system development, IP-core design and board design in the fields of:

- image processing
- communications
- consumer electronics
- industrial electronics.

## Barco Silex IP products

Barco Silex design expertise is also made available through a wide portfolio of IP products, with a strong focus on high performance, standardized image processing and encryption functions.

All these IP cores have been designed and fully validated by Barco Silex and are hardware proven, which guarantees high IP quality as well as best support during your integration phase.

Deliverables include:

- RTL Code or netlist (depending on license type)
- Functional simulation testbench
- Synthesis script
- Full documentation

For some of them, we can also provide you with simulation models and a design kit.

These "off the shelf", high quality IP cores provide you with the fastest and most efficient way of integrating complex functionalities on FPGAs or ASICs, while meeting short time to market constraints.

## More information

Order-reference: **BA318**

For additional information and other IP products contact:

Barco – Silex

e-mail: [barco-silex@barco.com](mailto:barco-silex@barco.com)

<http://www.barco-silex.com>

or the local Barco Silex design centers:

### Belgium

Scientific Park  
Rue du Bosquet 7  
1348 Louvain-la Neuve  
+32(0)10/45.49.04

### France

ZI Peynier- Rousset  
Route de Trets Imm CCE  
13790 Peynier  
+33(0)44/216.41.06