

DX-700

Next-generation LED Processor



The DX-700 is a multi-window video processor designed as a versatile front-end to all Barco LED products:

- Current LED products such as MiPIX, MiSTRIP, MiTRIX, DLite, OLite, SLite and iLite are supported via the DVI LED interface on the DVI Output Module.
- Next generation LED products such as the NX-4 are supported via the NNI LED interface on the NNI Output Module.

LED wall configuration and image processing functions are adjusted from the DX-700 front panel, or with Barco's Director Toolset.

BARCO

Visibly yours

System Overview

The DX-700 processor enables you to set up video walls, and define input sources and LED outputs with both precision and flexibility.

A wide number of flexible system configurations are supported. The DX-700's input and output modules are installed in "banks", consisting of one or more input modules, and either one or two output modules.

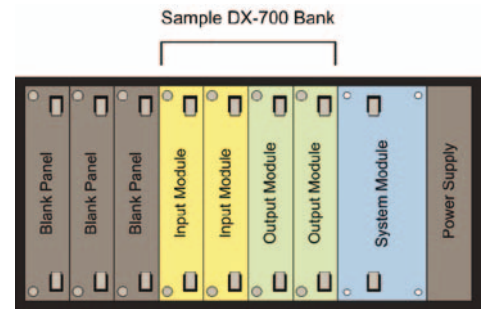
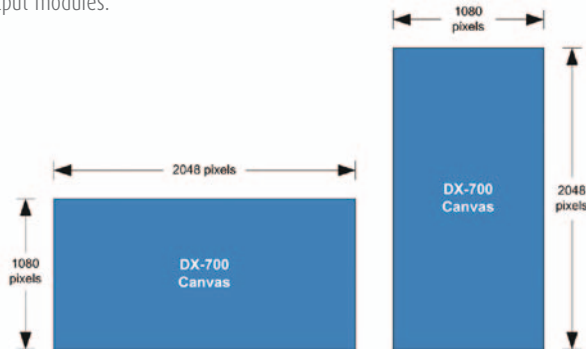

By definition, a "bank" is a way of combining inputs and outputs into independent video processors that are capable of driving one or more LED walls.

The DX-700's overall workspace is called the "canvas," the region on which you can configure inputs and outputs. Each bank provides you with a maximum canvas size of 2048 x 1080 pixels (or 1080 x 2048 pixels).

When using DVI output modules, the maximum output resolution is achieved with two modules. With NNI output modules, only one is required.

Within the DX-700's canvas, you can place up to six output regions, you can scale inputs to fit LED outputs precisely, or you can select just a portion of an input to fit a wall. To illustrate the DX-700's flexibility, two sample configurations are provided below.

Sample DX-700 Configuration 1: One output module drives three independent video walls

In this configuration, a single output module's three outputs are used independently — each connected to a different type of LED wall.

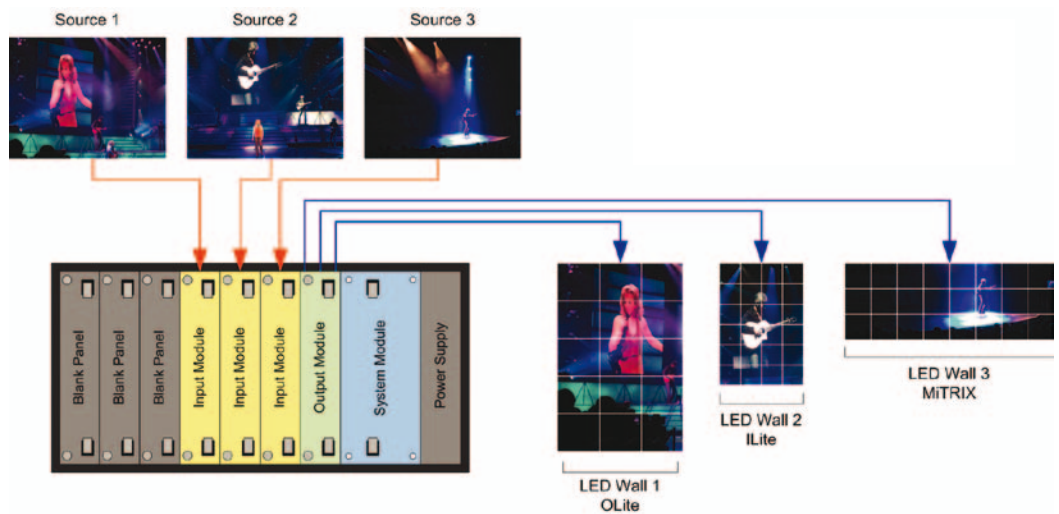

Sample DX-700 Configuration 2: One output module drives three "grouped" video walls to form one large wall

With each output, a single output module's can drive its three outputs are used as a group — with each output connected to a portion of a very large wall, comprised of the same type of tiles.

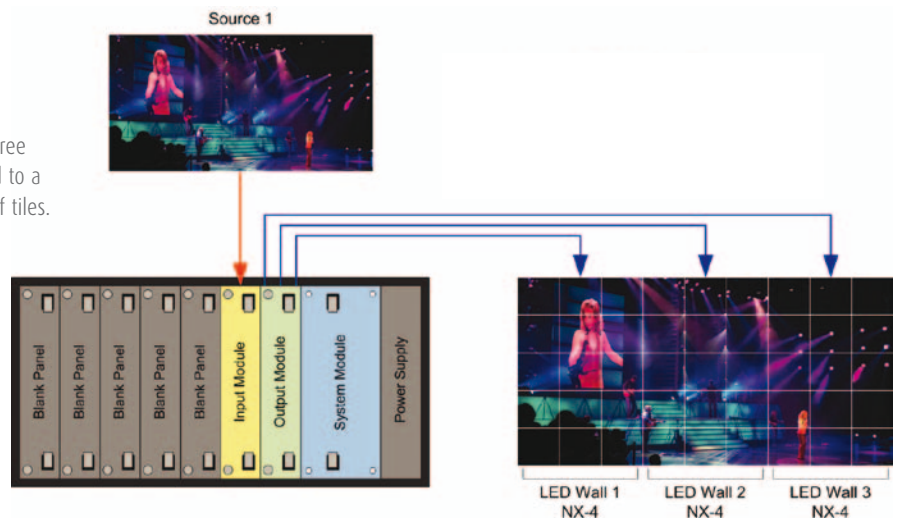

Features

Input Features

- Input modules provide “universal” connections for DVI (RGB or YCbCr), Dual-DVI (RGB), Component Analog (RGB or YPbPr), NTSC/PAL, CVBS or Y/C, SD-SDI, HD-SDI, and Dual HD-SDI formats. Multiple input modules can be assigned to a bank.
- All inputs except DVI provide a minimum 10-bit color depth, in either 4:4:4 or 4:2:2 format. An advanced motion-adaptive de-interlacer with diagonal filter converts interlaced or progressive segmented frame (PSF) inputs to progressive format.
- All processing is performed with a 12-bit minimum color depth.
- Dynamic contrast enhancement is available on any video input source.
- Input balancing can be applied to any input, with individual RGB adjustments.

Output Features

- Output modules are available in two formats: DVI (for current Barco tiles), and NNI (for next generation Barco tiles). Each module has three outputs that can drive independent LED walls, or which can be “grouped” to drive a single large LED wall.
- Up to two output modules can be included in a bank.
- Video layers can be alpha-blended (e.g., assigned an attribute of invisible, opaque, or any level in between), regardless of layer priority.
- Color-keying is supported. Any input module may be designated as a key source.
- A variety of digital video effects are supported, including freeze, strobe, and linear color transformations (e.g., monochrome and inverted video).

System Features

- Basic system configuration and adjustments are performed via front panel controls. Advanced configuration is performed using Director Toolset.
- Seven rear panel slots are provided for input and output modules. All modules are fully shielded and field-installable.
- Input and output modules can be configured into functional “banks” that create independent video processors capable of driving one or more LED walls.
- Ethernet, diagnostic, DMX and genlock ports reside on the System Module. Analog and digital monitor outputs are also provided.
- Rack-mountable chassis (5RU).

Genlock Features

- DX-700 can be genlocked to an external reference, to a selected input, or set to free-run.

Wizards

- Two convenient Wizards are provided. The Setup Wizard detects all tiles, configures outputs, and enables you to “group” outputs. The Input Wizard configures and scales inputs, and enables you to store “presets.”

DX-700 Configuration

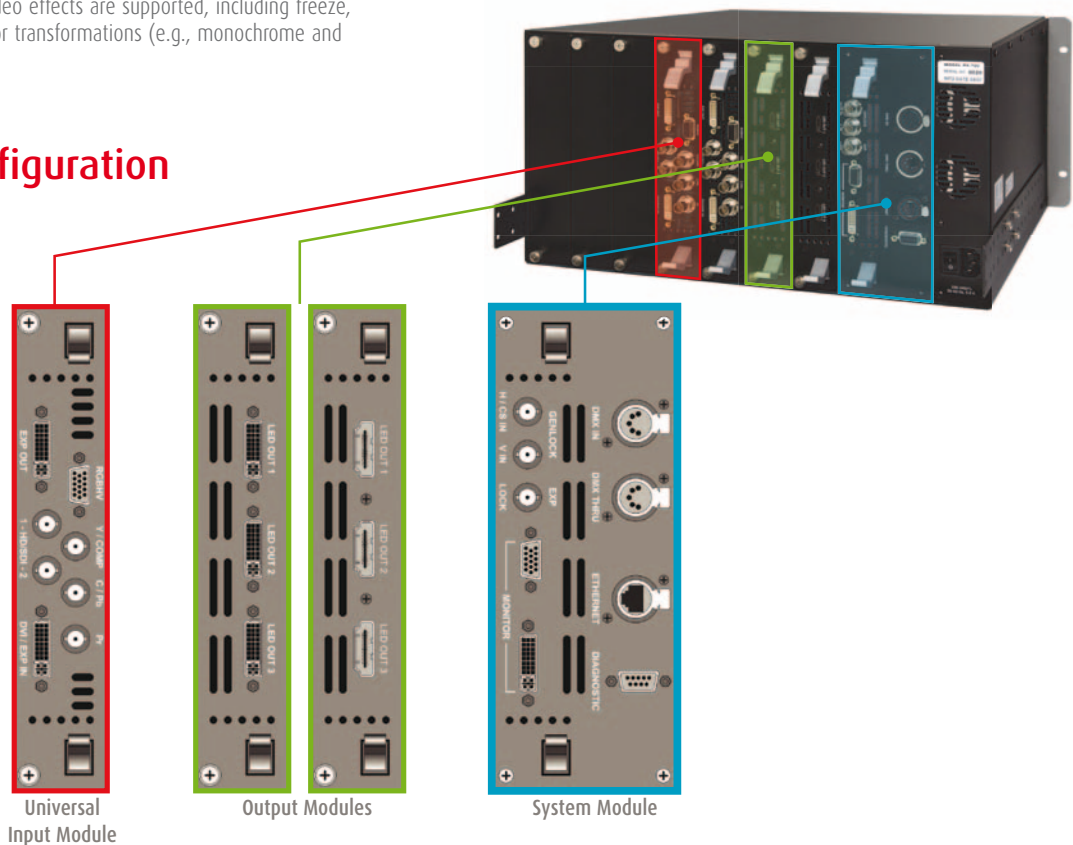

Specifications

INPUT MODULE	
1 x Analog input (HD-15)	<ul style="list-style-type: none"> All resolutions supported to a maximum rate of 240MHz (progressive or interlaced scan). 10-bits/color sampling
1 x 3-BNC input	<ul style="list-style-type: none"> All resolutions supported to a maximum rate of 240MHz (progressive or interlaced scan). 10-bits/color sampling Supports composite NTSC/PAL/Secam, S-Video (Y/C) and Component RGB or YPbPr w/Sync-on-G (Y) Supports Tri-level sync
1 x DVI Digital input	<ul style="list-style-type: none"> All resolutions supported to a maximum rate of 165MHz (single-link) or 240MHz (dual-link). Supports both RGB and YCbCr, progressive or interlaced. Supports single-link and dual-link Also used as Expansion Input port when linking units together
2 x HD/SD SDI input	<ul style="list-style-type: none"> 525/60 (NTSC) and 625/50 (PAL), HD 720p, per SMPTE 259M HD 720p per SMPTE 296M, HD 1080i per SMPTE 292M Supports single-link and dual-link Dual-link HD-SDI modes supported per SMPTE 372M: <ul style="list-style-type: none"> 1080p, 4:2:2 YCbCr, 10-bit up to 60Hz 1080i or 1080p/PsF up to 30Hz with: <ul style="list-style-type: none"> 10-bit 4:4:4 RGB or YCbCr 12-bit 4:4:4 RGB or YCbCr 12-bit 4:2:2 YCbCr
OUTPUT MODULE	
2 types of output cards are available.	<ul style="list-style-type: none"> Triple DVI-style connectors supporting the Barco Legacy 32MHz LED Output protocol. <ul style="list-style-type: none"> Each output can drive a different type of Barco LED product. Large displays can be driven by combining multiple outputs. 2 output cards (6 outputs) are required to output 2K x 1080 to 1080 x 2K. Triple HDMI-style connectors supporting the Barco high-resolution NNI LED output protocol. <ul style="list-style-type: none"> Large displays can be driven by combining multiple outputs. The 2K x 1080 to 1080 x 2K output resolution can be achieved by combining the 3 outputs on a single NNI Output Module.
USER CONTROL	
Front Panel Display	<ul style="list-style-type: none"> VGA touch panel Display, Display setup wizard, Source setup wizard, Preset management menu, Source alignment menu, Display management, DX-700 management
Front Panel Buttons	<ul style="list-style-type: none"> Six softkeys are used to access menus and activate functions. Five navigation buttons are used to navigate through menus and lists. Black button. This button places black on all outputs. Test pattern button. This button takes you directly to the Test Pattern Generator Menu. Presets button. This button takes you directly to the Preset Management Menu.
Remote Control	Fully controllable over IP
BASE UNIT	
Width	19" Rack
Height	5RU
Input/Output Connectors	<ul style="list-style-type: none"> All Input and Output connectors are located on the back. The connections with the system module are located on the back. <ul style="list-style-type: none"> RJ-45 connector for communication with DTS. Analog (HD-15) and Digital (DVI-I) monitor output connector are located on the back. DMX IN and DMX THROUGH connectors. DIAGNOSTIC RS232 connector (for system diagnostics only)
Power	100-240 VAC, 50-60 Hz, Auto selecting

Barco nv - Media & Entertainment Division

Noordlaan 5, 8520 Kurne, Belgium
 T +32 56 36 80 47 - F +32 56 36 83 86
 email: sales.event@barco.com

11101 Trade Center Drive,
 Rancho Cordova, CA 95670, USA
 T +1 916 859 2500 - F +1 916 859 2515

BARCO

Visibly yours