

# CEILING MOUNT CM100-LCD

## A Rugged Ceiling Support System for Large BARCO Projectors

The CM100-LCD enables mounting of any BARCO 5000/8000/9000 Series projector to the ceiling, and to adapt the projector perfectly for any mounting requirement.

### Features

- A pulley system facilitates lifting, installation and maintenance of the projector
- Adjustable height from direct ceiling mount to 735mm (29")
- The projector can easily be levelled through four corner screws
- After fitting to the ceiling, it is possible to move the projector until projection is perpendicular to the screen
- Slide-in of the projector and automatic lock system through two security pins
- It is possible to lift a dual projector stack assembly (Multi-Functional Frames must be used)

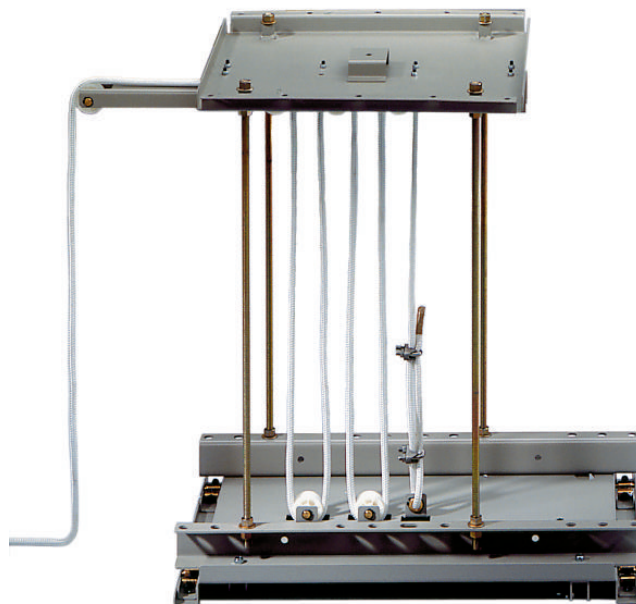

# Technical Specifications

Dimensions	inch	mm
Upper plate (A):	20x17.3	510x440
Screwed rods (B):	28.9	735
Lower plate (C):	30x20.1x3	726.5x512x77

The length of the threaded rods is adjustable for installation requirements.

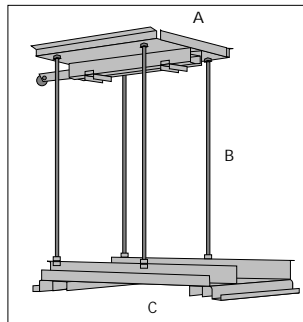

## Weight

Net weight: 79.0 lbs. - 36.0 kg

Shipping weight:  
88.0 lbs. - 40.0 kg

Upper plate: 15.9 lbs. - 7.2 kg

Lower plate: 37.9 lbs. - 17.2 kg

Maximum load:  
441.0 lbs. - 200.0 kg

The ceiling should be capable of supporting a weight of at least 1764 lbs. / 800 kg<sup>(1)</sup>

## Order Information

CM100 for LCD projectors<sup>(2)</sup>  
 CM100 with Pulley R9829620  
 CM100 without Pulley R9829621

Projection Stacking Frame  
 5000/8000 Series R9829210

Multi-Functional Frame  
 9000 Series R9829650

## Compatibility

The CEILING MOUNT CM100 LCD can be used with 5000/8000/9000 Series projectors.

For dual projection configurations with 5000/8000 series projectors, BARCO's Stacking Frames should be used. With 9000 series projectors, BARCO's Multi-Functional Frames should be attached to the ceiling mount.

(1)The ceiling should be capable of supporting a weight of at least 1600 kg (3527 lbs) when carrying a dual projector.

(2) The ordernumber includes the adaptor plate.



BARCO Projection Systems is an ISO 9001 registered company.

The information and data given are typical for the equipment described. However any individual item is subject to change without any notice.

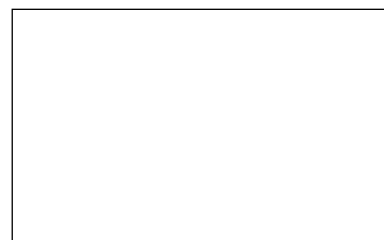

BARCO Projection Systems  
 Head Office  
 Noordlaan 5 8520 Kuurne, Belgium  
 Tel: +32 / 56 / 368 211  
 Fax: +32 / 56 / 351 651  
 E-mail: sales.bps@barco.com  
 Visit BARCO at the web: <http://www.barco.com>

